

100VFI series

Single & Dual Output DC/DC Converter



DESCRIPTIONS

The 100VFI Model 1.5 watt DC/DC's are specially designed to provide ultra-high levels of isolation 6000VDC in a low profile 24 pin DIP package. The series consists of 18 models with input voltages of 5V, 12V and 15V, and offers regulated output voltages of 5V, 12V, 15V, $\pm 5V$, $\pm 12V$ and $\pm 15V$.

The 100VFI series is an excellent selection for railroad/transportation equipment, medical equipment subsystems, process/machine control equipment and automatic test instrumentation.

OUTPUT CHARACTERISTICS

	Min	Typ	Max	Unit/Comments
Output Voltage Set Point	± 2.0	± 4.0		% Output voltage at nominal line & FL
Output Voltage Balance (Duals)	± 0.5	± 2.0		% Equal Output Loads
Line Regulation	± 1.2	± 1.5		%; % Change / Percentage change in Input voltage
Load Regulation (5 Vout)	± 7.0	± 10.0		% Output voltage measured from FL to 20% load
Load Regulation (± 5 Vout)	± 8.0	± 12.0		
Load Regulation (12, ± 12 Vout)	± 6.0	± 8.0		
Load Regulation (15, ± 15 Vout)	± 4.0	± 6.0		
Ripple/Noise	30	40		mV p-p, Nom.Line @FL, 20MHz B.W., using 1 μ f bypass capacitor
Ripple/Noise		50		mV p-p, Over Line, Load & Temp., 20 MHz B.W., using 1 μ f bypass capacitor
Overload Protection	120			%Rated Output Load
Short Circuit Protection				Continuous, Automatic Recovery
Temperature Coefficient	± 0.01	± 0.02		% per degree C

FEATURES

- High Isolation - 6000 VDC
- Up to 75 % Efficiency
- Single and Dual Output, 1.5 watt converter
- Available in 5, 12, and 15 VDC Inputs
- Short Circuit Protection
- Low Isolation Capacitance

INPUT CHARACTERISTICS

	Min	Typ	Max	Unit/Comments
Input Voltage				
5 VDC Input Models	4.5	5	5.5	VDC
12 VDC Input Models	10.8	12	13.2	VDC
15 VDC Input Models	13.5	15	16.5	VDC
Input Fuse Requirements				
5 VDC Input Models		1000		mA; Slow blow type
12 VDC Input Models		250		mA; Slow blow type
15 VDC Input Models		250		mA; Slow blow type
Reverse Polarity Input Current			0.5	Amp
Short Circuit Input Power			1000	mW
Input Filter				Pi Filter

GENERAL CHARACTERISTICS

	Min	Typ	Max	Unit/Comments
Switching Frequency	50		100	kHz
Test Isolation Voltage	8,000			VDC, 1 minute
Rated Isolation Voltage	6,000			VDC, 1 minute
Isolation Resistance	10,000			Mohm, 500VDC
Isolation Capacitance		10	15	pF, 100kHz, 1Volt
MTBF (MIL-HBK-217F)	2			Million Hours, +25°C, Ground Benign

ENVIRONMENTAL SPECIFICATIONS

	Min	Typ	Max	Unit/Comments
Operating Temp. Range	-40		+85	°C; Ambient
Storage Temp. Range	-55		+125	°C
Relative Humidity			+95	% Humidity; non-condensing
Cooling				Free-Air Convection

PHYSICAL CHARACTERISTICS

	Unit/Comments
Case Size	1.25 X 0.8 X 0.4 inches (31.8 X 20.3 X 10.2 mm)
Case Material	Non-Conductive Black Plastic
Flammability	UL94V-0
Weight	12 Grams

OUTLINE DRAWING

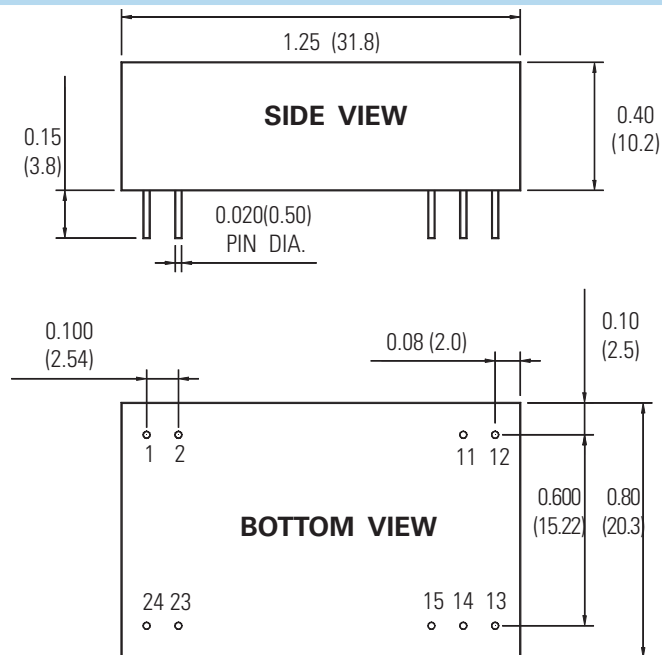

PIN OUT CHART

Pins	Single	Dual
1	+ Vin	+ Vin
2	+ Vin	+ Vin
11	+ Vout	+ Vout
12	+ Vout	+ Vout
13	- Vout	Common
14	- Vout	Common
15	No Pin	- Vout
23	- Vin	- Vin
24	- Vin	- Vin

Notes:

1. Unless otherwise specified dimensions are in inches (mm).

Tolerances	Inches	mm
	X.XX = ±0.02	X.X = ±0.5
	X.XXX = ±0.010	X.XX = ±0.25
Pin :	±0.002	±0.05

All specifications are typical at nominal input, nominal load and 25° C unless otherwise specified.
External, low ESR, 10 microfarad (minimum) capacitor across output is recommended for operation.

How To ORDER

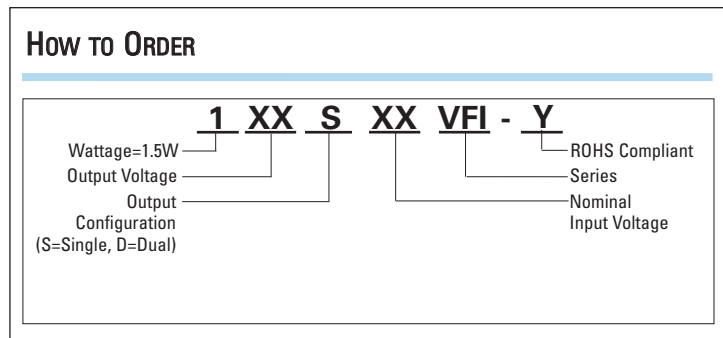

MODEL SELECTION CHART

Model	Nominal Input Voltage (VDC)	Output Voltage (VDC)	Full Load Output Current (mA)	No Load Input Current (mA)	Full Load Input Current (mA)	Reflected Ripple Current (mA)	Efficiency @ FL (%)
105S5VFI	5	5	300	50	400	30	75
112S5VFI	5	12	125	50	400	30	75
115S5VFI	5	15	100	50	400	30	75
105D5VFI	5	±5	±150	50	400	30	75
112D5VFI	5	±12	±63	50	400	30	75
115D5VFI	5	±15	±50	50	400	30	75
105S12VFI	12	5	300	30	167	25	75
112S12VFI	12	12	125	30	167	25	75
115S12VFI	12	15	100	30	167	25	75
105D12VFI	12	±5	±150	30	167	25	75
112D12VFI	12	±12	±63	30	167	25	75
115D12VFI	12	±15	±50	30	167	25	75
105S15VFI	15	5	300	30	133	20	75
112S15VFI	15	12	125	30	133	20	75
115S15VFI	15	15	100	30	133	20	75
105D15VFI	15	±5	±150	30	133	20	75
112D15VFI	15	±12	±63	30	133	20	75
115D15VFI	15	±15	±50	30	133	20	75

DERATING CURVES

MODEL 100VFI

